

EC-05

Auto Start Module for Gasoline Engine Generators

Features

- Suitable for key switch type gasoline engine generators without automatic start and stop function
- Choke control makes unit especially suitable for use in cold regions
- Small size, low cost, low power consumption and high stability
- Terminal blocks for easy installation and maintenance
- Built-in DC power supply protection fuse for safety
- Three engine cranking attempts
- Engine running and Failed Start LED Status Indicators
- Three time delay adjustment potentiometers
- UL94-V0 epoxy encapsulation for use in harsh environments



Specifications

DC Power Input	Voltage 9 to 36 Vdc	Start Signal Output	7 Amps @ 12/24 Vdc (Battery + output)
AC Power Input	Voltage 5 to 300 Vac 1 Phase	Stop Signal Output	7 Amps @ 12/24 Vdc (Battery - output)
	Frequency 50/60 Hz	Choke Signal Output	7 Amps @ 12/24 Vdc (Battery + output)
Static Power Consumption	Less than 0.2 watts	DC Power Supply Fuse	5 x 20mm S505-10A slow-blow type

Time Delay Settings and Adjustments

Stop (engine stop delay)	1 to 20 seconds (stepless adjustment)
Choke delay	1 to 20 seconds (stepless adjustment)
Start delay	1 to 10 seconds (stepless adjustment)
Time between start attempts	6 seconds (cannot be adjusted)
Engine start attempts	3 times (cannot be adjusted)

LED Status Indicators

Running (green)	Flashing : unit is in Standby mode Illuminated : unit is running
Fail (red)	Engine start failure

Dimensions

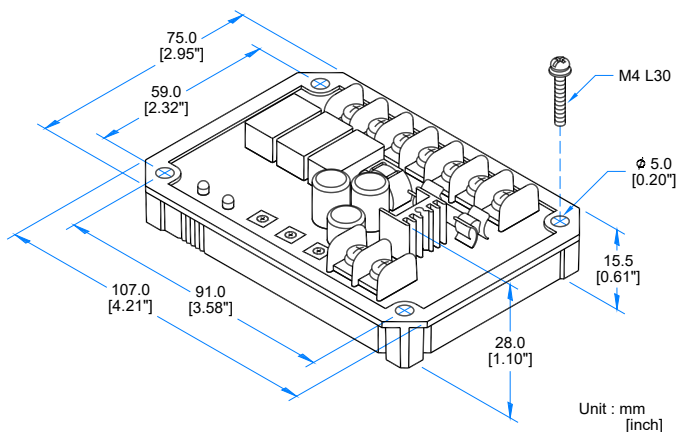

Environment

Operating Temperature	-20 to +70 °C
Relative Humidity	Max. 95%
Vibration	5.5 Gs @ 60 Hz

Physical Specifications

Dimensions	107.0 (L) x 75.0 (W) x 28.0 (H) mm 4.21 (L) x 2.95 (W) x 1.10 (H) inch
Weight	170 g +/-2% 0.37 lb +/-2%

